

perpetua[®]

we had to invent it



"The pencil - what my grandfather used to call by the latin name 'lapis' has always been part of my life. Hb, 2b, 4b and 6b for soft shades; 2h for technical drawings. Micro leads, maxi leads. And then, the opportunity to design MY pencil. How could I ever say no?"

Marta Giardini
Designer of Perpetua the pencil

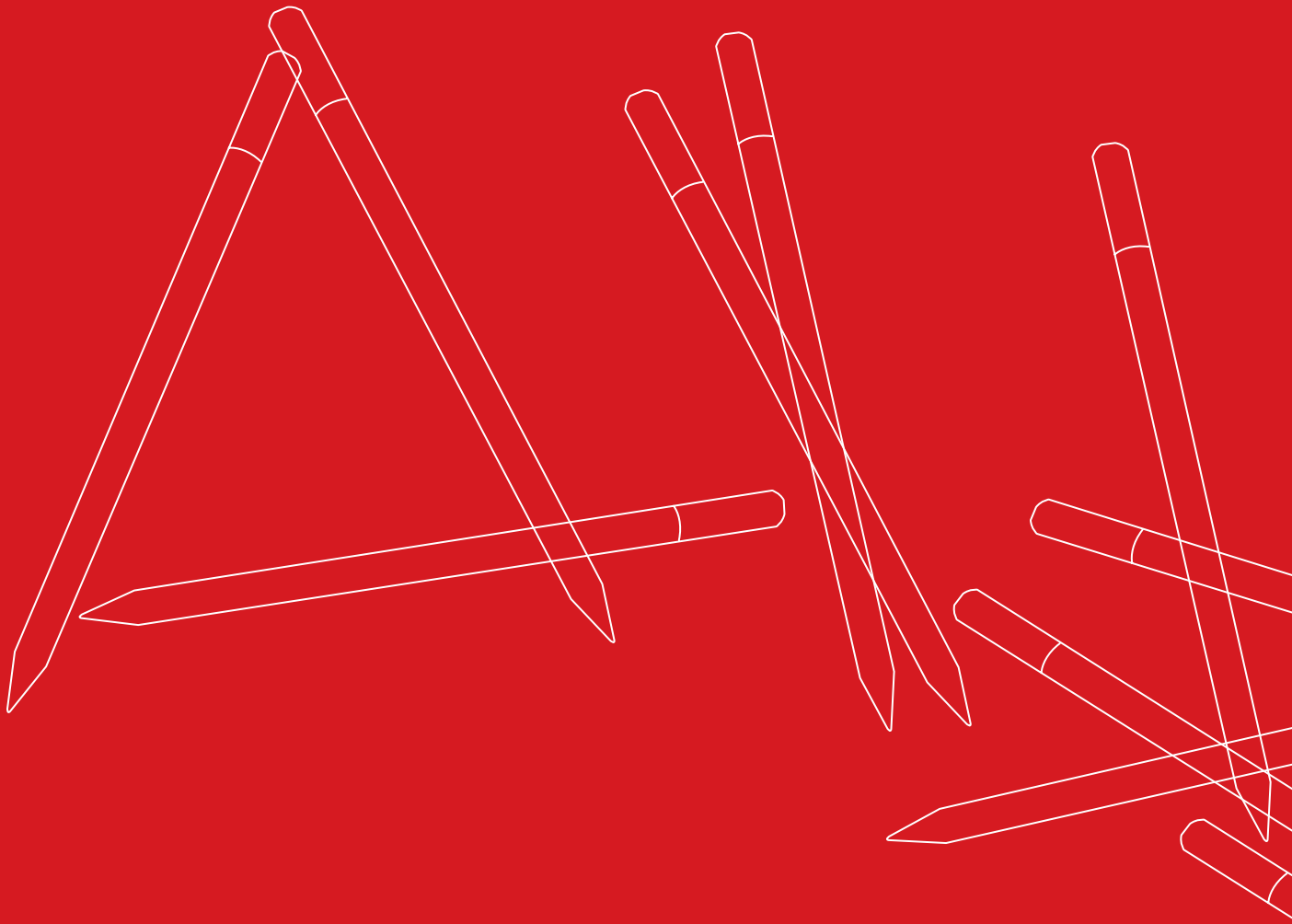

perpetua[®]

Perpetua is a purpose brand of Alisea, a company that since 1994 has been thinking, designing and producing in Italy design objects made with the exclusive use of recovered and recycled materials, aimed at corporate communication.

Perpetua is an advanced way of thinking materials and objects. Through research, creation, innovation and technology, raw materials waste - otherwise destined to be destroyed - are given a second chance. Useful, original, functional and innovative design objects are born in full respect of people and our Planet: Perpetua the pencil is the first of them.

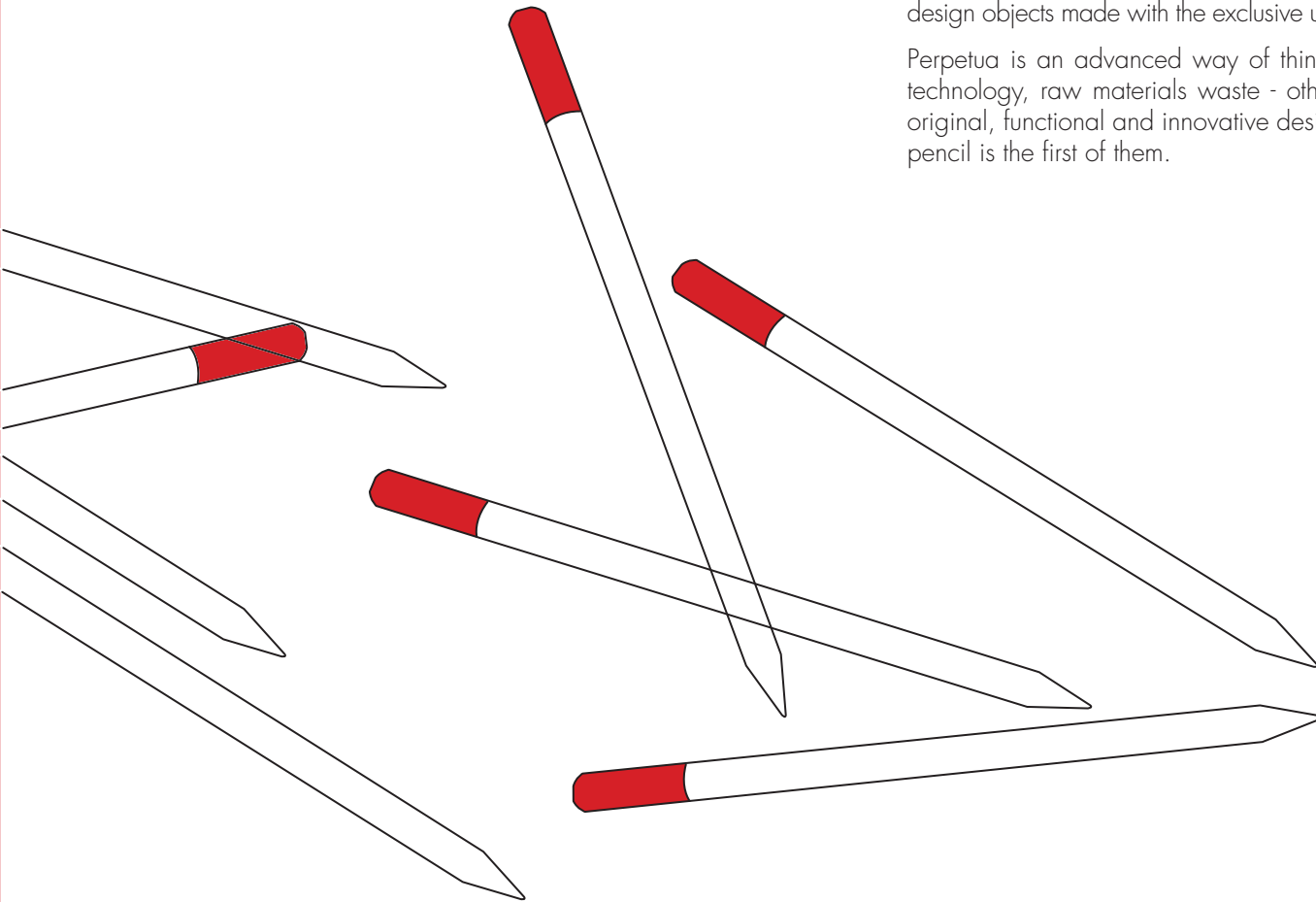

Perpetua® the pencil

A real revolution in the world of writing. For the first time, recovered graphite is combined with a special compound which makes it stronger, shock resistant and clean, as it does not get your hands dirty. Perpetua the pencil is a product and production process patent, and the only pencil made in Italy.

Disposing by writing

We have developed a new way of reusing graphite powder, the waste of industrial production, otherwise destined to be buried underground. By using Perpetua you are disposing 1.5 grams of graphite. The exclusive production technology makes the traditional wood casing obsolete, therefore giving birth to a more sustainable method of producing pencils - without the need to cut down trees. Perpetua offers a new and innovative way of writing: it respects our Planet and proves that small gestures can make a difference.

Until today, thanks to the Perpetua International Community, we have recovered together over 20 tons of graphite powder.

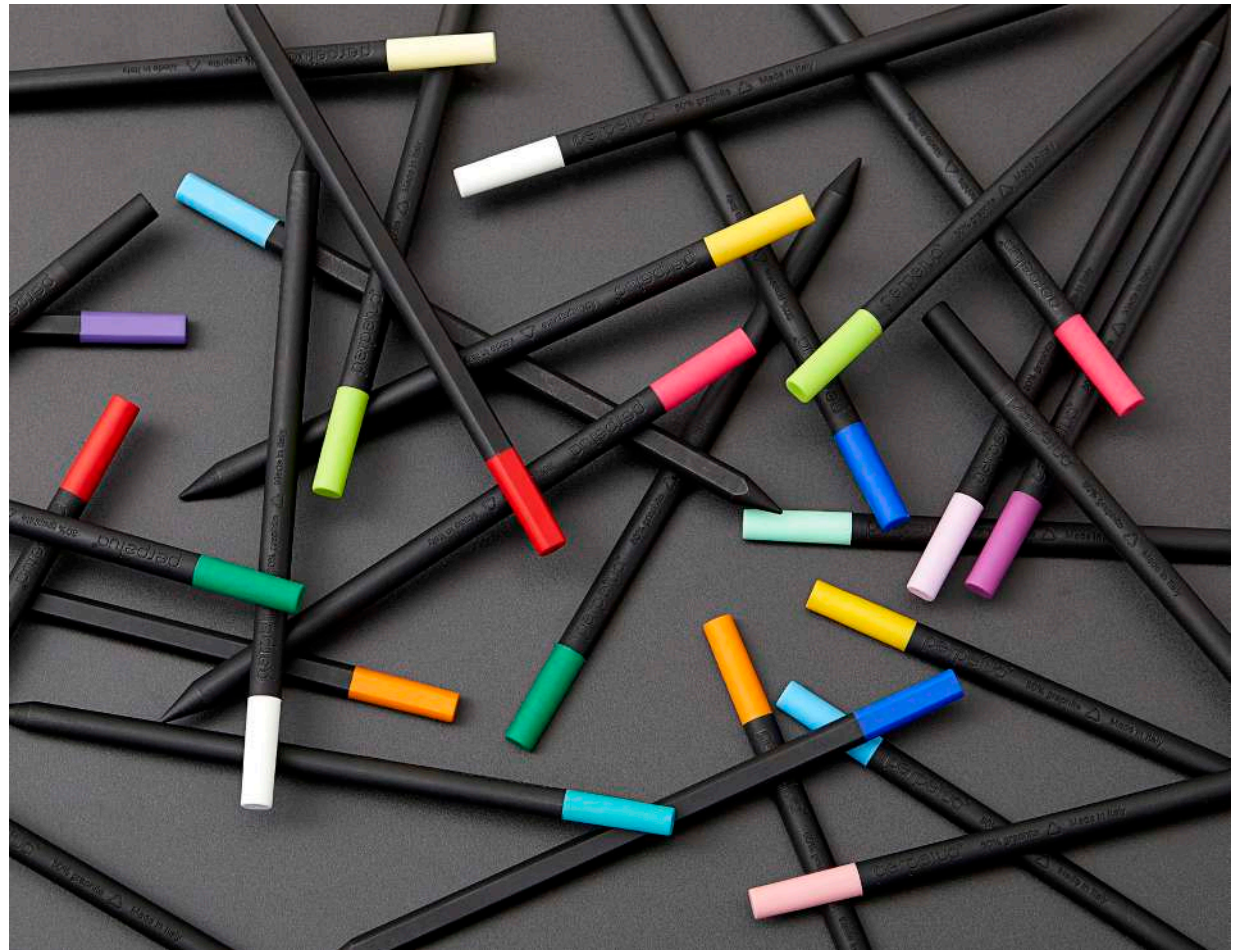



PERPETUA the pencil

Material

Perpetua is made of Zantech®, an innovative material composed of 80% graphite powder - recovered from the industrial production of electrode - otherwise destined to the landfill.

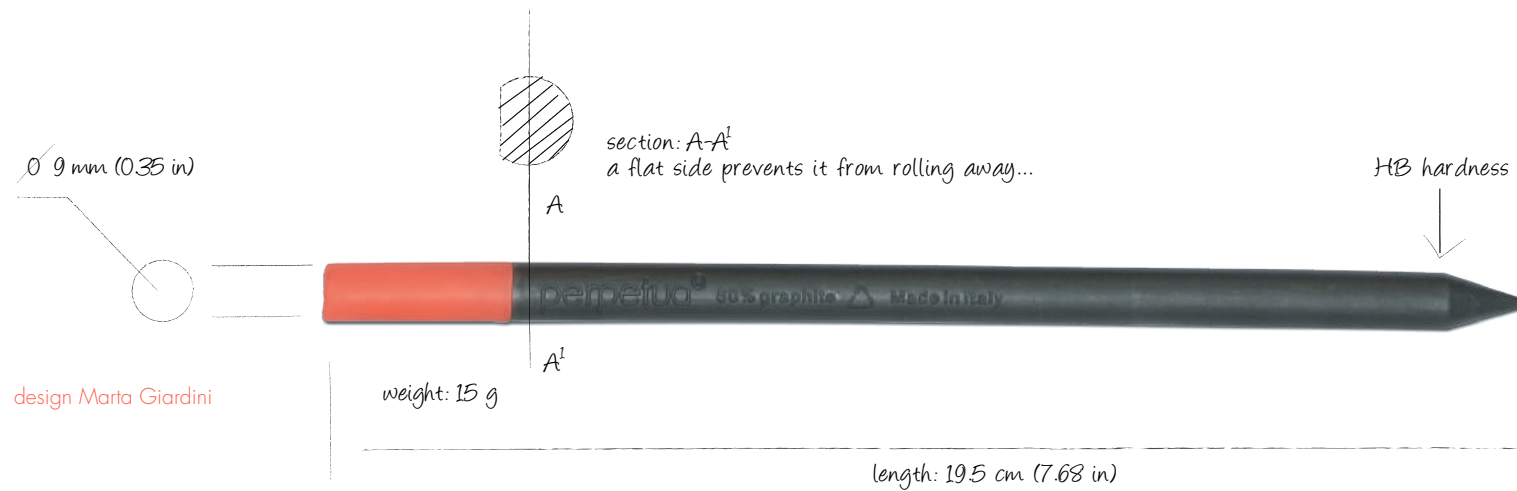

Features

- Perpetua is long-lasting, it writes 20 times more if compared to traditional pencils: 1120 km (IUAV data);
- It can be sharpened as other pencils, but it writes even without tip or if cut in halves;
- It doesn't dirty your hands;
- It won't break if it falls (without the use of glue or protective coatings);
- Its FDA certified eraser forms a single body with the writing part. It is not glued but moulded directly with the graphite;
- It has a flat side (grip control) which prevents it from rolling away;
- It is atoxic, clean and suitable for children and their way of writing.





Natural graphite stone



Graphite electrode



Graphite powder recovered from industrial production of electrodes



Zantech® - 80% recycled graphite powder



Rubber + red masterbatch
FDA Certified



Perpetua® the pencil

Packaging

Perpetua has an exclusive black cardboard packaging - FSC certified, 400 grams (Favini paper mill) - thought to become a postcard to write your message. The O-rings, used in the packaging, are produced in Italy with natural rubber and coloured with natural ingredients. They can be worn as multi-coloured bracelets.

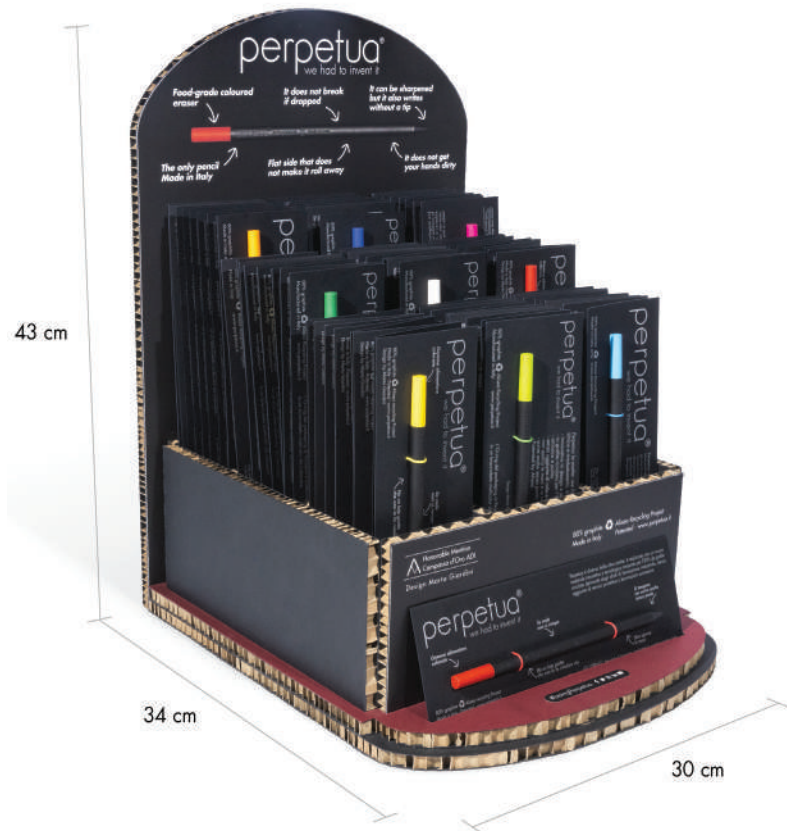

Eraser

Perpetua's eraser is available in ten different colours: yellow, orange, red, fuchsia, blue, light blue, lime green, green, white and black. Every year, four new colours, chosen among the season trends, enrich the collection creating special limited editions.

Display

Perpetua's POS display is made in honeycomb cardboard, an extremely resistant material, light and durable. 100% recycled, it describes the features of Perpetua in different languages. Available in 2 formats which can host 48 or 72 Perpetua. Designed by eng. Marco Neffat.

Awards

- 2019 – Selected for ADI Design Index with WRAD g_jacket endorsed by Perpetua exclusively for Starbucks Reserve Roastery.
- 2018 – Sustainable Development Award in waste and resources category with g_pwdr Technology, awarded by Fondazione per lo Sviluppo Sostenibile in collaboration with Ecomondo.
- 2018 – Good Energy Award – Bernoni Grant Thornton in the Manufacturing and Technology category thanks to g_pwdr Technology.
- 2017 – Unicom National Union of Communication Companies "Italy who spreads sustainability".
- 2016 – Honorary Mention Compasso d'Oro, the most ancient and authoritative international design award.
- 2015 – Best of the Year Award, Green Innovation category, New York.

perpetua[®] limited edition

Every year, four new eraser colours, chosen among the season trends, enrich Perpetua's collection creating special limited editions for collectors and supporters.

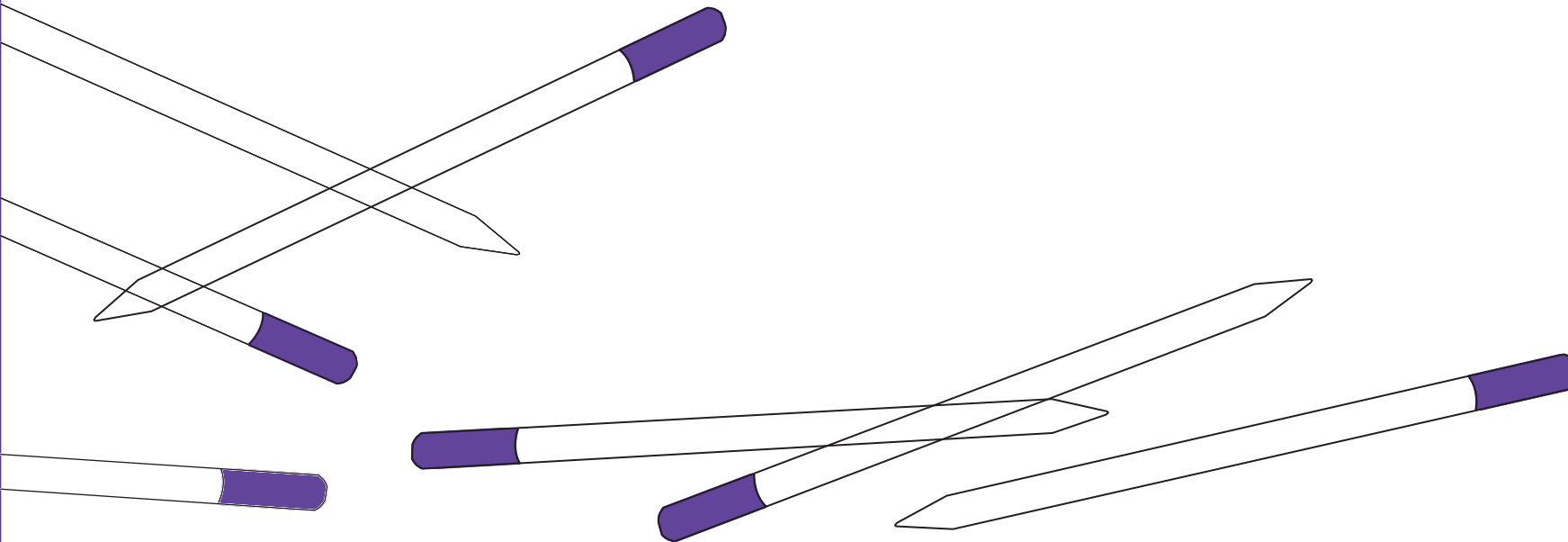

Perpetua Portofino collection

An exclusive collection of 4 new eraser colours inspired by the colourful architecture and unique buildings of Portofino historic downtown. A limited edition created in collaboration with the designer Marta Giardini.

Only 4000 Perpetua have been created for each colour (pink, mulberry, light blue, purple), anticipating the new trends for 2019 and becoming a temporary addition to the other 10 already existing colours.

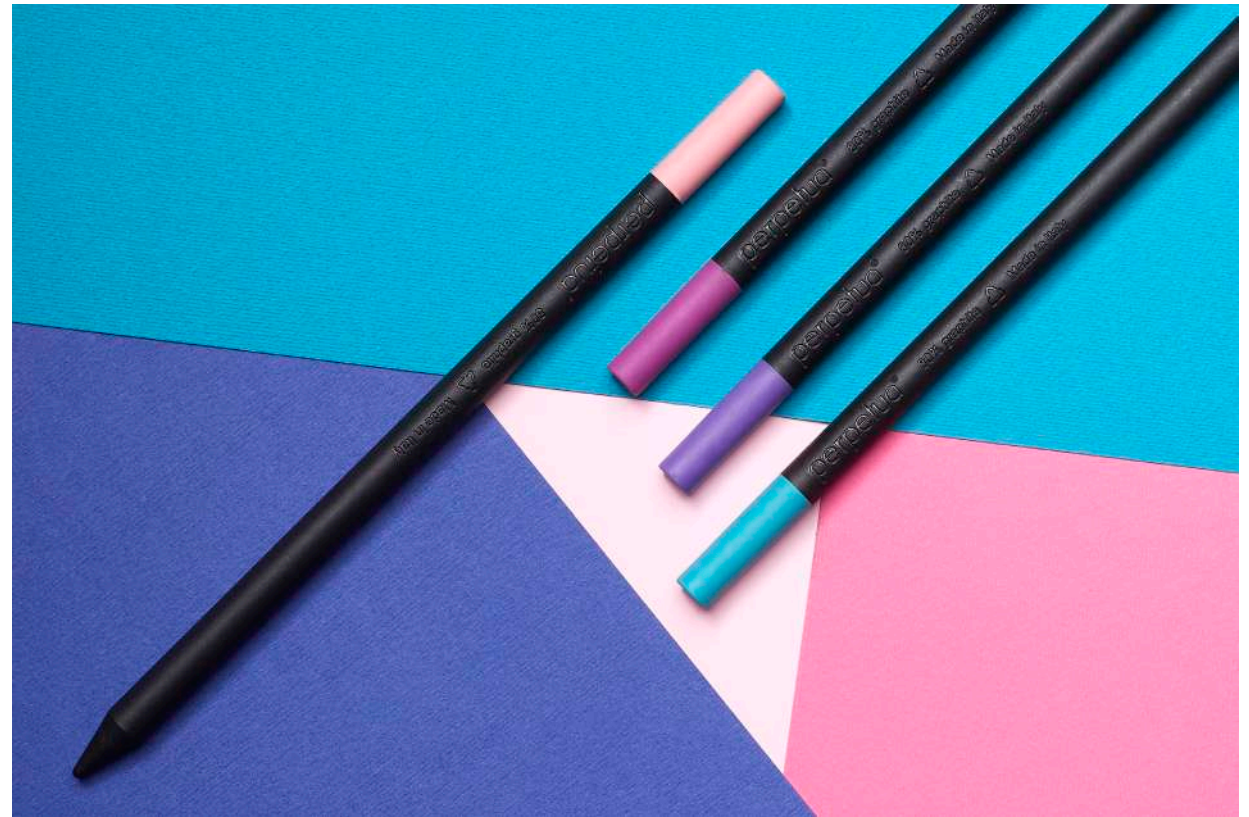

Perpetua Sweet life Collection 2018

Perpetua sweet life collection is a limited edition created together with the designer Marta Giardini. Only 3000 Perpetua have been produced for each of the 4 pastel colours (yellow, green, light blue, pink).

They have been added to the 10 existing colours. Each Perpetua has engraved its own production number on the flat side.

perpetua® we had to invent it

80% graphite www.perpetua.it
Manufactured in Italy

Honorable Mention
Compasso d'Oro ADI



Portofino Collection limited edition 4000 esemplari



perpetua® we had to invent it

Unica e rivoluzionaria, è diversa perché:

- innovativa in design e tecnologia
- in grafite riciclata per l'80%
- se cade non si rompe
- scrive anche senza punta
- non sporca le mani e
- senza aggiunta di colle e vernici protettive
- Patented

Perpetua the pencil, we had to invent it!
Unique and revolutionary, it is different because:

- it is innovative in design and technology
- it is made of 80% recycled graphite
- it falls it does not break
- it writes even without tip
- it doesn't get your hands dirty
- no glues or protective coatings were added
- Patented

Perpetua la matita, prima non c'era!
Unica e rivoluzionaria, è diversa perché:

- innovativa in design e tecnologia
- in grafite riciclata per l'80%
- se cade non si rompe
- scrive anche senza punta
- non sporca le mani e
- senza aggiunta di colle e vernici protettive
- Patented

Perpetua the pencil, we had to invent it!
Unique and revolutionary, it is different because:

- it is innovative in design and technology
- it is made of 80% recycled graphite
- it falls it does not break
- it writes even without tip
- it doesn't get your hands dirty
- no glues or protective coatings were added
- Patented

Honorable Mention
Compasso d'Oro ADI



Portofino Collection limited edition 4000 esemplari

perpetua® we had to invent it

80% graphite www.perpetua.it
Manufactured in Italy

Honorable Mention
Compasso d'Oro ADI



design by Marta Giardini

Perpetua la matita, prima non c'era!
Unica e rivoluzionaria, è diversa perché:

- innovativa in design e tecnologia
- in grafite riciclata per l'80%
- se cade non si rompe
- scrive anche senza punta
- non sporca le mani e
- senza aggiunta di colle e vernici protettive
- Patented

Perpetua the pencil, we had to invent it!
Unique and revolutionary, it is different because:

- it is innovative in design and technology
- it is made of 80% recycled graphite
- if it falls it does not break
- it writes even without tip
- it doesn't get your hands dirty
- no glues or protective coatings were added
- Patented

Gli "O-RING" del pack di Perpetua si trasformano in braccialetti multicolor da indossare.

The "O-RINGS" of Perpetua's pack become multi-colored bracelets to wear.

Portofino Collection limited edition 4000 esemplari

perpetua® we had to invent it

80% graphite www.perpetua.it
Manufactured in Italy

Honorable Mention
Compasso d'Oro ADI



design by Marta Giardini

Perpetua la matita, prima non c'era!
Unica e rivoluzionaria, è diversa perché:

- innovativa in design e tecnologia
- in grafite riciclata per l'80%
- se cade non si rompe
- scrive anche senza punta
- non sporca le mani e
- senza aggiunta di colle e vernici protettive
- Patented

Perpetua the pencil, we had to invent it!
Unique and revolutionary, it is different because:

- it is innovative in design and technology
- it is made of 80% recycled graphite
- it falls it does not break
- it writes even without tip
- it doesn't get your hands dirty
- no glues or protective coatings were added
- Patented

Gli "O-RING" del pack di Perpetua si trasformano in braccialetti multicolor da indossare.

The "O-RINGS" of Perpetua's pack become multi-colored bracelets to wear.

Portofino Collection limited edition 4000 esemplari



perpetua® we had to invent it

80% graphite www.perpetua.it
Manufactured in Italy

Honorable Mention
Compasso d'Oro ADI



design by Marta Giardini

Perpetua la matita, prima non c'era!
Unica e rivoluzionaria, è diversa perché:

- innovativa in design e tecnologia
- in grafite riciclata per l'80%
- se cade non si rompe
- scrive anche senza punta
- non sporca le mani e
- senza aggiunta di colle e vernici protettive
- Patented

Gli "O-RING" del pack di Perpetua si trasformano in braccialetti multicolor da indossare.

Portofino Collection limited edition 4000 esemplari

perpetua® we had to invent it

80% graphite www.perpetua.it
Manufactured in Italy

Honorable Mention
Compasso d'Oro ADI



design by Marta Giardini

Perpetua la matita, prima non c'era!
Unica e rivoluzionaria, è diversa perché:

- innovativa in design e tecnologia
- in grafite riciclata per l'80%
- se cade non si rompe
- scrive anche senza punta
- non sporca le mani e
- senza aggiunta di colle e vernici protettive
- Patented

Gli "O-RING" del pack di Perpetua si trasformano in braccialetti multicolor da indossare.

Portofino Collection limited edition 4000 esemplari

perpetua® we had to invent it

80% graphite www.perpetua.it
Manufactured in Italy

Honorable Mention
Compasso d'Oro ADI



design by Marta Giardini

Perpetua la matita, prima non c'era!
Unica e rivoluzionaria, è diversa perché:

- innovativa in design e tecnologia
- in grafite riciclata per l'80%
- se cade non si rompe
- scrive anche senza punta
- non sporca le mani e
- senza aggiunta di colle e vernici protettive
- Patented

Perpetua the pencil, we had to invent it!
Unique and revolutionary, it is different because:

- it is innovative in design and technology
- it is made of 80% recycled graphite
- it falls it does not break
- it writes even without tip
- it doesn't get your hands dirty
- no glues or protective coatings were added
- Patented

Gli "O-RING" del pack di Perpetua si trasformano in braccialetti multicolor da indossare.

The "O-RINGS" of Perpetua's pack become multi-colored bracelets to wear.

Portofino Collection limited edition 4000 esemplari

perpetua® we had to invent it

80% graphite www.perpetua.it
Manufactured in Italy

Honorable Mention
Compasso d'Oro ADI



design by Marta Giardini

Perpetua la matita, prima non c'era!
Unica e rivoluzionaria, è diversa perché:

- innovativa in design e tecnologia
- in grafite riciclata per l'80%
- se cade non si rompe
- scrive anche senza punta
- non sporca le mani e
- senza aggiunta di colle e vernici protettive
- Patented

Gli "O-RING" del pack di Perpetua si trasformano in braccialetti multicolor da indossare.

Portofino Collection limited edition 4000 esemplari



perpetua[®] special edition

The special editions narrate Perpetua's ability to reinvent itself, be versatile and surprising. Each edition represents Perpetua's capability to innovate, while maintaining the core values at the base of its philosophy.

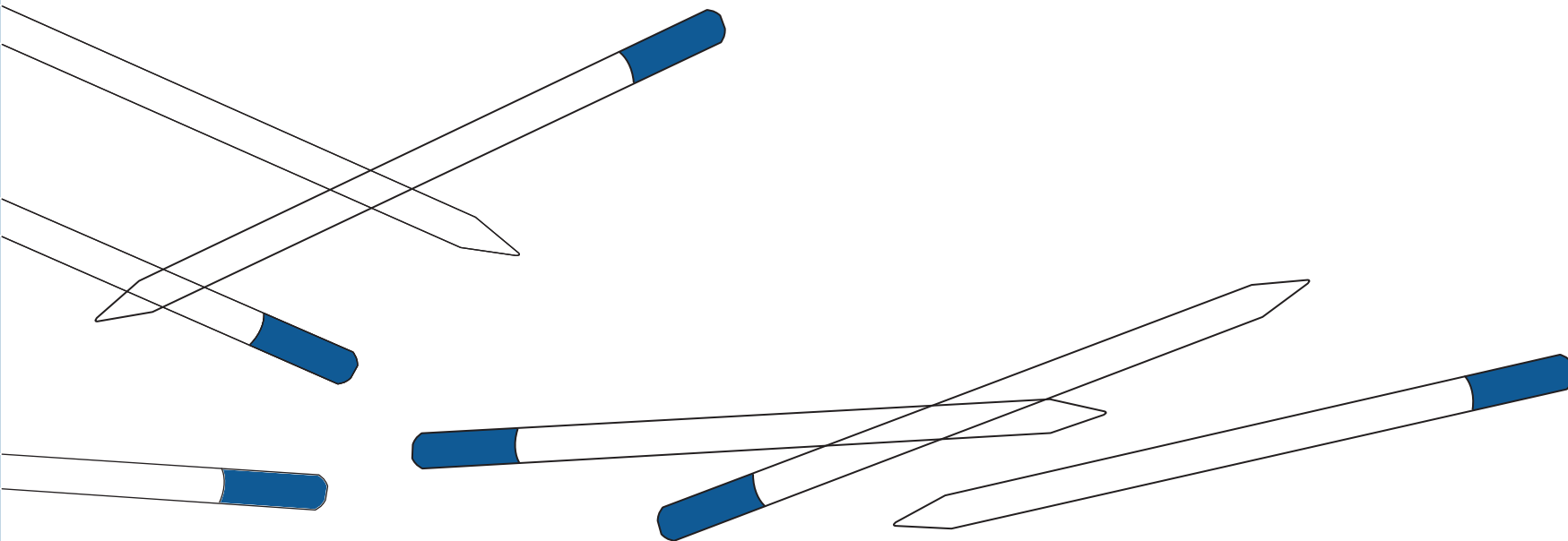

Perpetua back to school and work

Perpetua the pencil is for everyone! For both left and right-handed. The idea behind its special packaging considers not only the hand you use to write with, but also the one you use to sharpen your pencil.

Idea

Choose the yellow sharpener if you are left-handed or the red sharpener if you are right-handed.

With the use of the sharpener it is possible to give Perpetua a thinner mark - although it has been created to write until the last gram of graphite without the need of being sharpened.

A dedicated packaging highlights Perpetua's unique and extraordinary qualities for both children and adults.

Sharpener

We wanted the sharpener to be produced by Stabilo. Founded in 1885, it was the first company which designed a complete line of ergonomic tools with specific characteristics for both left and right-handed users. Perpetua's sharpener has a solid and resistant blade that ensures a smooth, accurate cut and supports the movement of the hand.



Perpetua glitter

Thanks to Perpetua glitter, your pencil becomes a jewel. Like a charming and outgoing young lady, Perpetua loves to enhance her character and to express her style through small and essential details that make her unique. This time, Perpetua surprises with the sparkling and original glitter edition look: the decoration of Perpetua glitter is obtained by combining creek's sand – sifted and cleaned – and flakes of recovered and reused coloured aluminum.

Decoration

The decoration is applied entirely by Nico, a goldsmith craftsman who uses a traditional manual technique, the same used to glaze pearls. Nature, recycling, artisan and goldsmith know-how give life to a design object ideal for writing, perfect for an exclusive gift or to collect.

Colours

Perpetua glitter edition is available in 7 coloured decorations: gold, dark silver, light silver, bronze, red, blue and black.

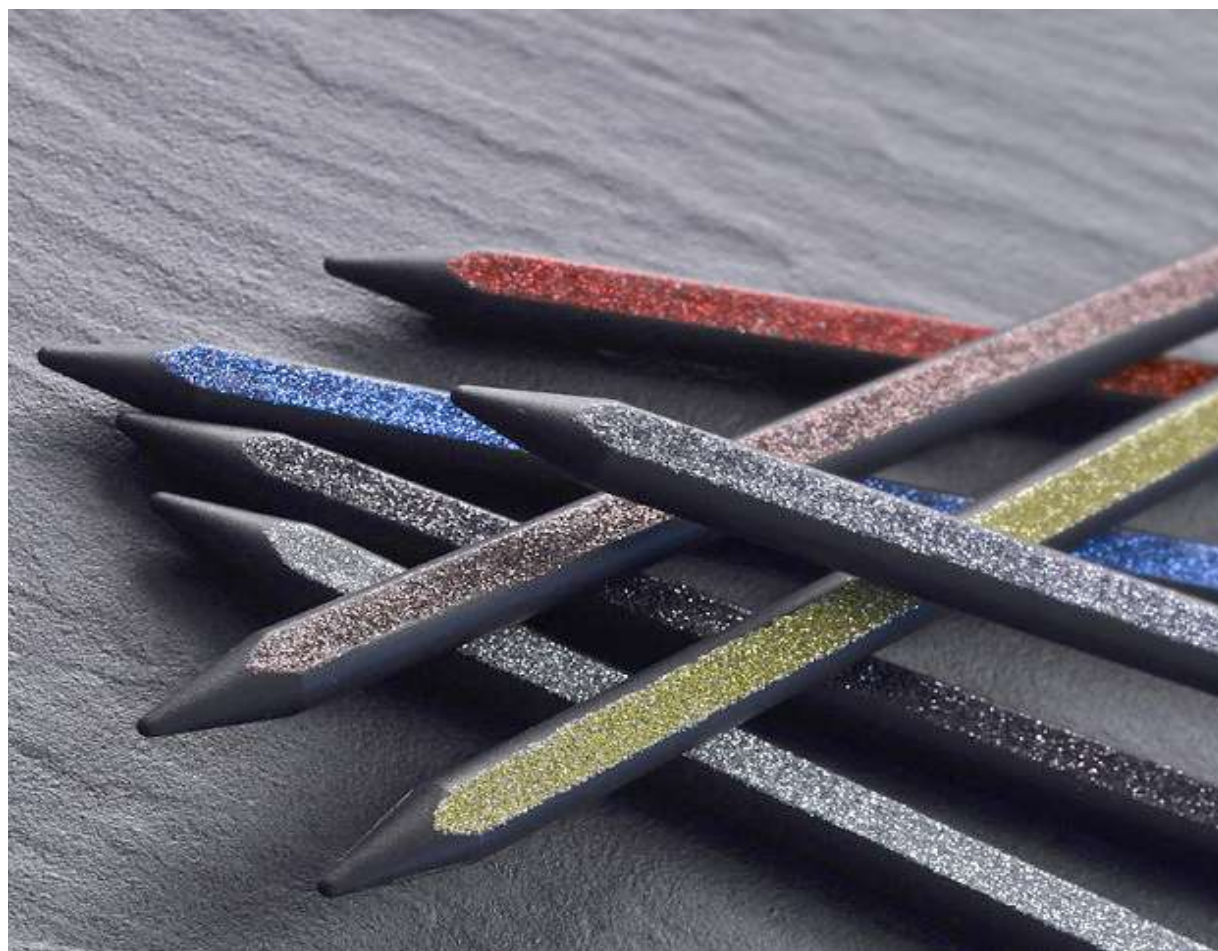

Perpetua lumina

Perpetua lumina is a “bright view” of the future, the result of a research and development project on green energy carries out by Lucedentro, a company devoted to the development of renewable energy. An idea which goes beyond the technologies of the past re-inventing them in full respect of our Planet. This innovation was achieved in collaboration with researchers, designers and architects, shedding a new light on the world of writing.



Eraser

The eraser of Perpetua lumina is the result of sustainability, photoluminescence and technological innovation applied to bioplastics. It is made with a particular bioplastic (obtained by using ingredients from renewable sources), which allows it to capture and retain both natural and artificial light which becomes visible in the dark - with an intensity that gradually decreases.

A charming and magical fluorescent blue or green light, a guide in the night, an original and unusual element for adults, a friend against the fear of the dark for the youngsters.

Packaging

Perpetua lumina's packaging is made in FSC paper and printed with a special metallic effect. It details all the features that make Perpetua unique.

Display

Perpetua lumina display stand – FSC Certified - is made in recycled and coupled cardboard, an extremely resistant material, light and durable. 100% recycled, it expresses Perpetua's message in different languages. It is designed to host 48 Perpetua lumina. Designed by Franco Chiani.



There's something magical about an object whose light doesn't die, emanating a free and clean energy, building a bridge between day and night, drawing an imaginary border of light.



g_cork: design beyond form

g_cork, a stopper that writes.

At first glance it might seem like a simple stopper, but g_cork is not just this: it writes just like Perpetua the pencil thanks to the combinations of two patents of innovative production processes in circular economy. The two patents are Zantech (patent by Alisea) and Sughera (patent by Mixcycling), composed of 70% granules recovered from cork processing which come together thanks to an innovative NGS (No Glue System) co-injection system.

The iconic shape of the head prevents the stem from coming into contact with surface impurities. Flat side that prevents it from rolling away. Can write. Non-toxic. Colored with FDA certified ingredients, g_cork is a design stopper, pleasant to the eye and to the touch and respectful of the planet we live in.



g_bag: dyed with recycled graphite

g_bag is made with g_pwdr Technology, an innovative production process that allows you to recycle waste graphite powder in the fabric dyeing phase. (patented by Alisea) Compared to traditional dyeing techniques, g_pwdr creates a positive impact because it reduces water consumption by 90%, it reduces the waste of electricity by 47% and it does not use chemical additives and pigments.

The fabric treated with g_pdwdr is characterized by the unique grey colour that cannot be obtained with any chemical dyeing system. Softness, obtained without the use of softeners but only through the lubricating properties of graphite. A single coat, not replicable, due to the abrasive characteristics of graphite powder.

Its dimensions are: 36,5x40 + 6cm; shoulder strap: 7x90cm.
g_bag was born in Italy.

SoloPerpetua: only for creative minds

SoloPerpetua is a new object that tells the story of Made in Italy design and innovation and is the result of the symbiosis of innovative production processes shared between Alisea and Pennelli Faro.

Solo® (Patented by Pennelli Faro) is a monomaterial brush made of 100% PBT, an innovative material made of 60% post-consumer PET. Perpetua® (Patented by Alisea) is the pencil made in Zantech, an innovative material produced using 100% graphite powder recovered from industrial production of diamond tools' waste.



Its single flat side created by the designer Marta Giardini makes its design unique and recognizable. Particular and pleasant (grip control) solo® offers perfect adhesion to any type of surface.

Comparable to the 2b hardness of traditional pencils, it is designed for writing, drawing, blending and watercolouring...but who says solo® can't also be used as a common make-up brush?

perpetua[®] recorder the magnetic notebook

In the transition towards change we break habits, innovate traditions and get rid of the weights of many objects, to respect the environment, restore and recycle activating a virtuous circular economy. This is our challenge. Perpetua recorder the magnetic notebook is the perfect result of this process.

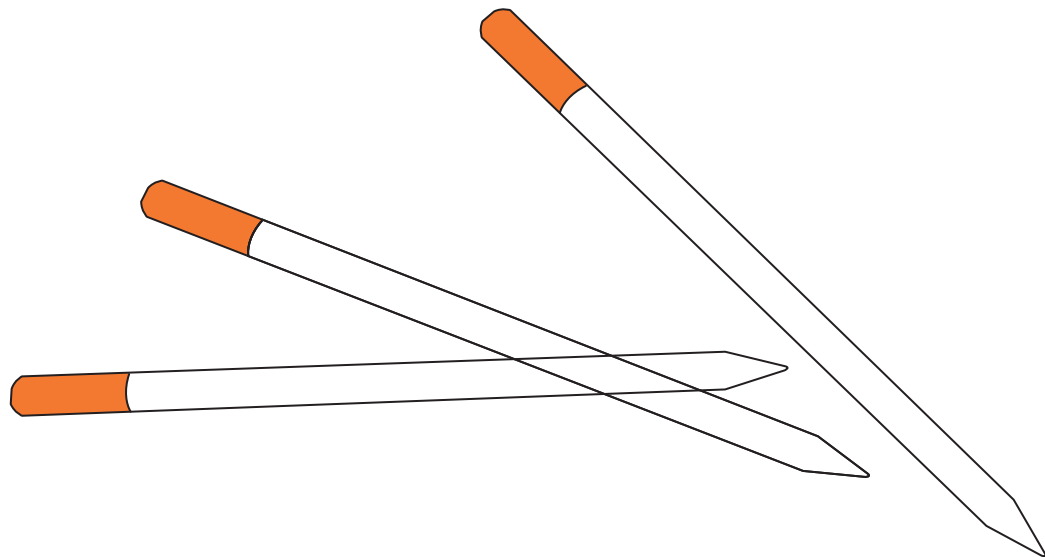
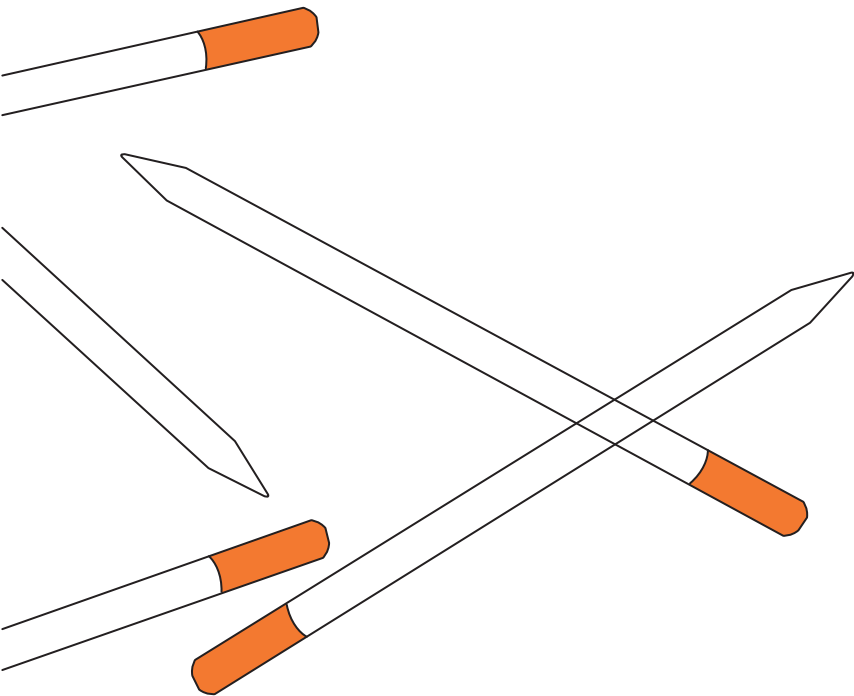

Technology and materials

Graphite and steel rewrite the laws of attraction.

Perpetua recorder is a magnetic notebook that combines patents and innovative technologies, made in Italy. A unique writing tool where the cover – which uses a thin strip of steel (patented) 60% derived from the recovery and recycling of metal scraps – attracts magnetically Perpetua the pencil.

The cover of Perpetua recorder is made of Jacron, a unique paper, in appearance and touch similar to leather. It is washable and does not tear. 100% recyclable.

The inner pages are made of recycled paper and printed in production plants powered by a latest generation photovoltaic system that contributes to a reduction in CO2 emissions of 760,000 kg / year.

Dimensions: 15x21 cm, 128 sheets.



The cover of Perpetua recorder, created by the designer Marta Giardini, is a tribute to the rotating sets of Kubrik's masterpiece 2001: A Space Odyssey.

Concept

Thanks to recorder we choose to write and share, where, when and with whom we want, our stories, our dreams and our future.

In this way we are always free to connect with our thoughts and our creativity without the need for wi-fi or electricity.

We want to create and develop innovative technologies to rediscover the skill of our hands, our mind and our ideas. It doesn't matter who we are or where we come from. We can always make the difference.





Perpetua recorder: the materials

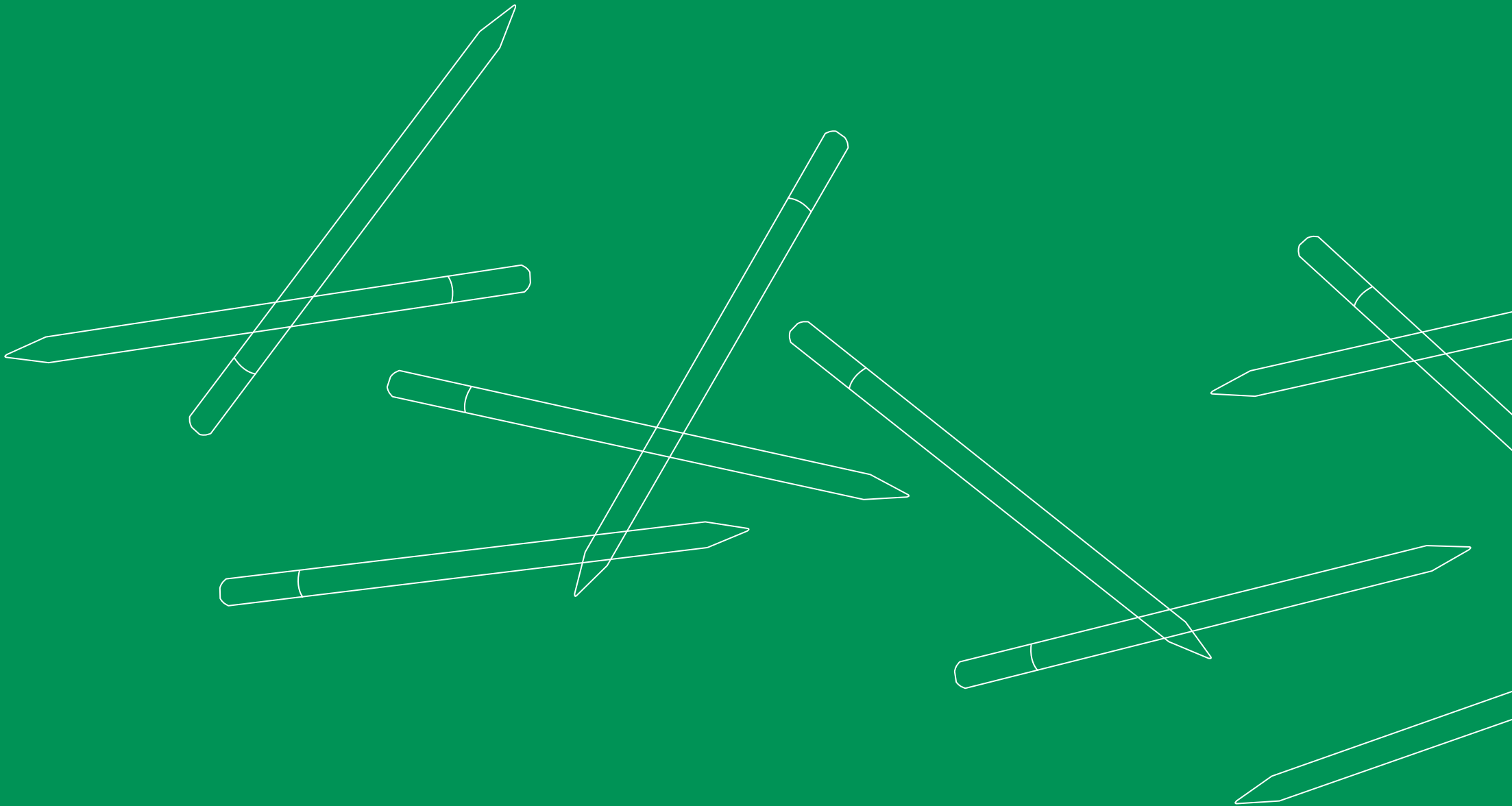

perpetua[®] accessories

Perpetua the pencil is innovation, design and respect for the environment. Its accessories want to follow its distinctive features and amplify its message. That of Perpetua is a family which continues to grow while maintaining the core values on which it is founded.

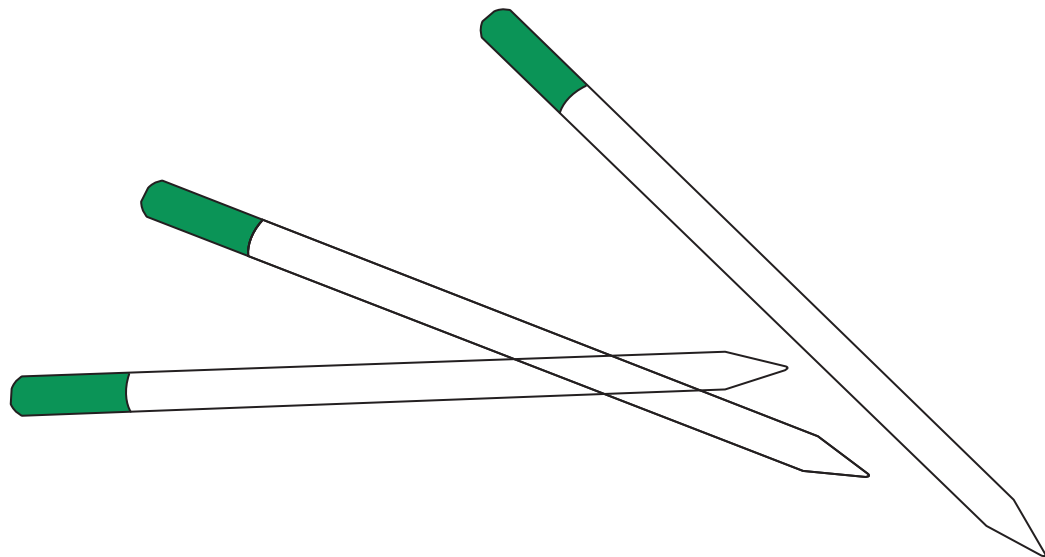
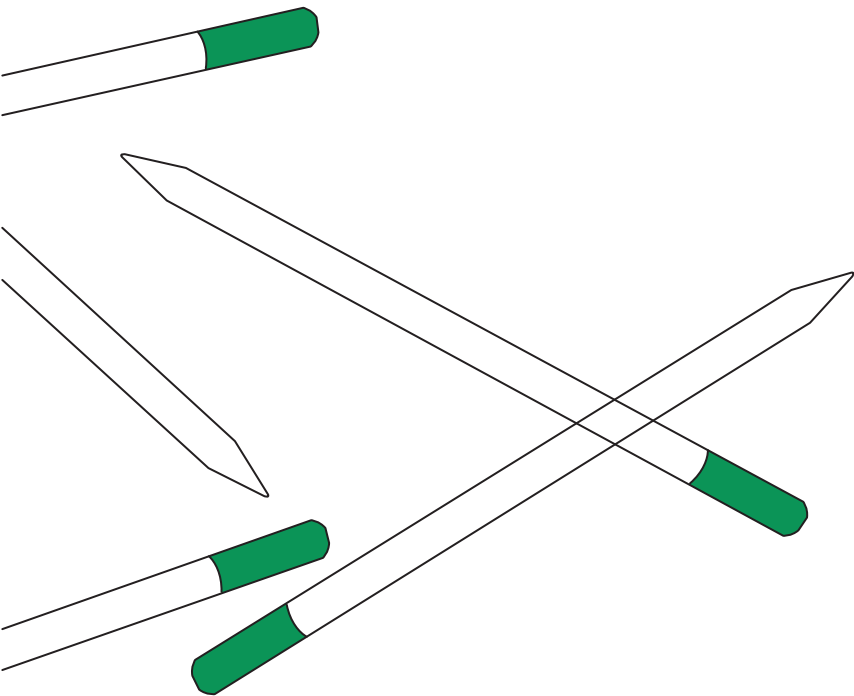

Perpetua the notebook

Perpetua the notebook is different from all the others, its cover is made of a special relief paper: Ecophilosophy. Created in the '60s and originally used for industrial bags to hold and store heavy and humid products such as flour, wheat, glues and cement. The cover of the notebook is printed with eco-friendly inks in solar-powered plants.

The inner pages are made of recycled paper.

Available in 4 different graphics designed by Marta Giardini

Perpetua the notebook is certified:  printed with the sun

Dimensions: 15x21 cm, 32 sheets.

O-rings

The two O-rings, which seal Perpetua the notebook, are completely made in Italy with natural rubber and coloured with natural ingredients. Originally they were black hydraulic seals. Today, thanks to Perpetua, they become multi-coloured bracelets to be worn.

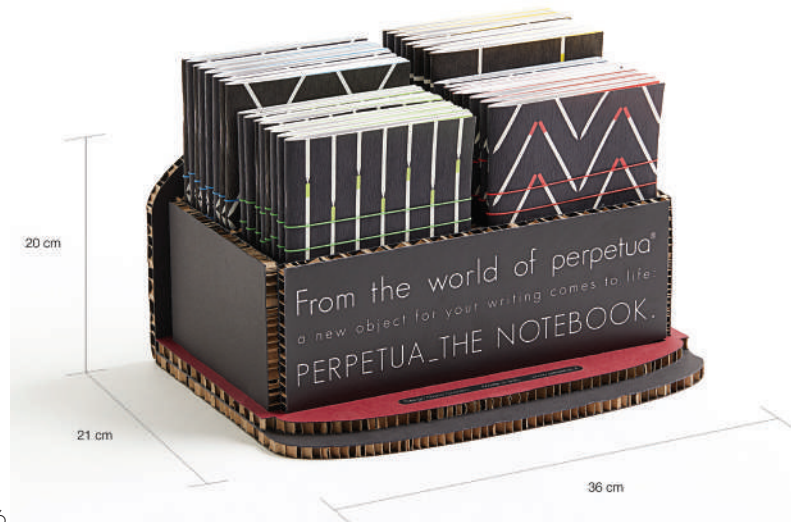
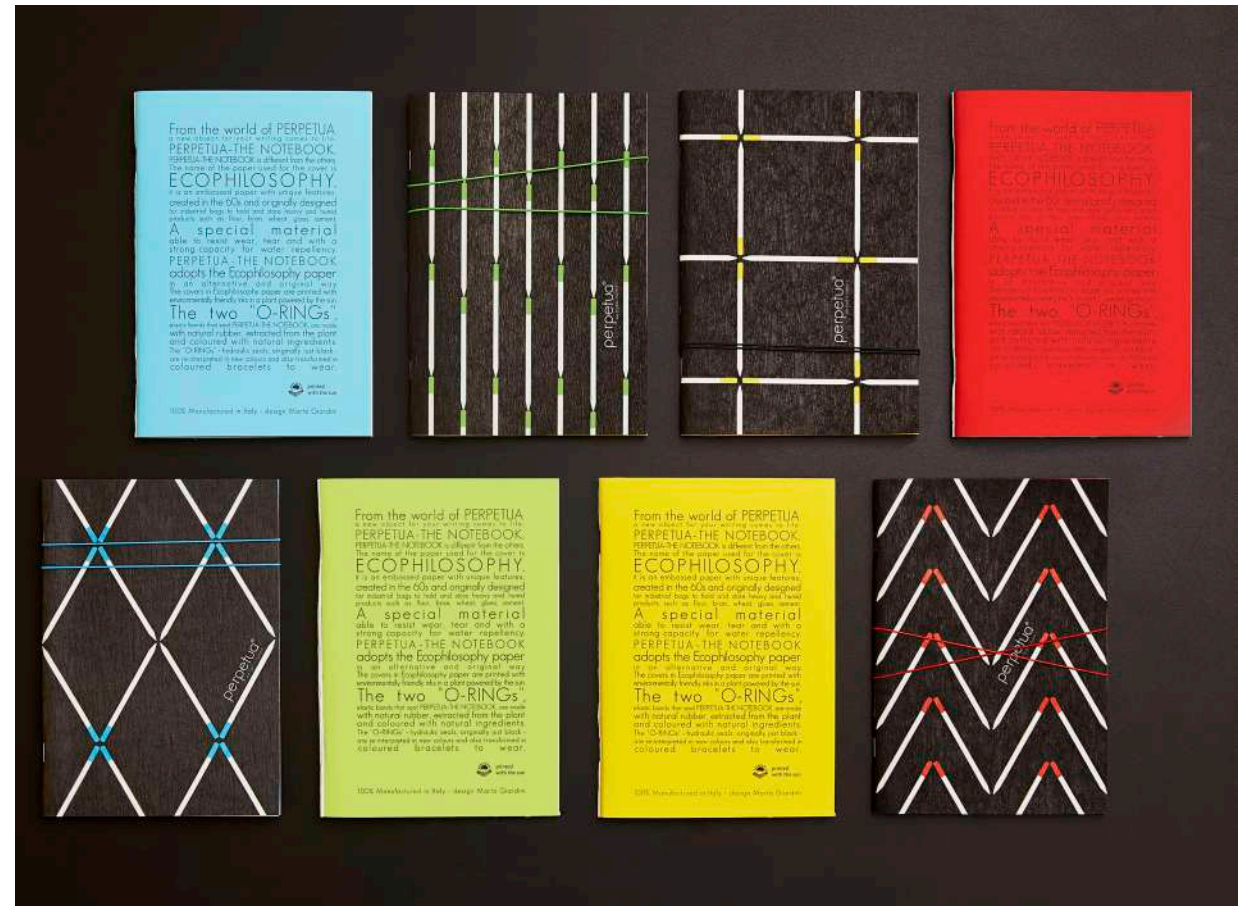

Display

The POS display is made in honeycomb cardboard, an extremely resistant material, light and durable. 100% recycled, it is available in different languages and can host up to 32 notebooks. Designed by eng. Marco Neffat.

Perpetua g_case

g_case is unique and revolutionary: it is available in 4 different graphics printed with g_ink, a pigment made with recycled graphite powder, the same used for Perpetua the pencil, which offers a perfect alternative to chemical dyes.

The cotton - we use to produce it - is 50% recycled. ICEA Certified. To make g_case more practical, its designer Marta Giardini has added a band which becomes a convenient ergonomic handle. g_case has also a red and black rubber zip. Perpetua g_case, born in Italy.

Dimensions: 28x17 cm.

Socially made in Italy

g_case is entirely sewn by hand, in collaboration with Socially Made In Italy, a non-profit organization that promotes the work of women in Italian prisons.

Ethics, fashion and human rights produce a virtuous combination that provides work for 60 women in 8 craft laboratories of excellence.

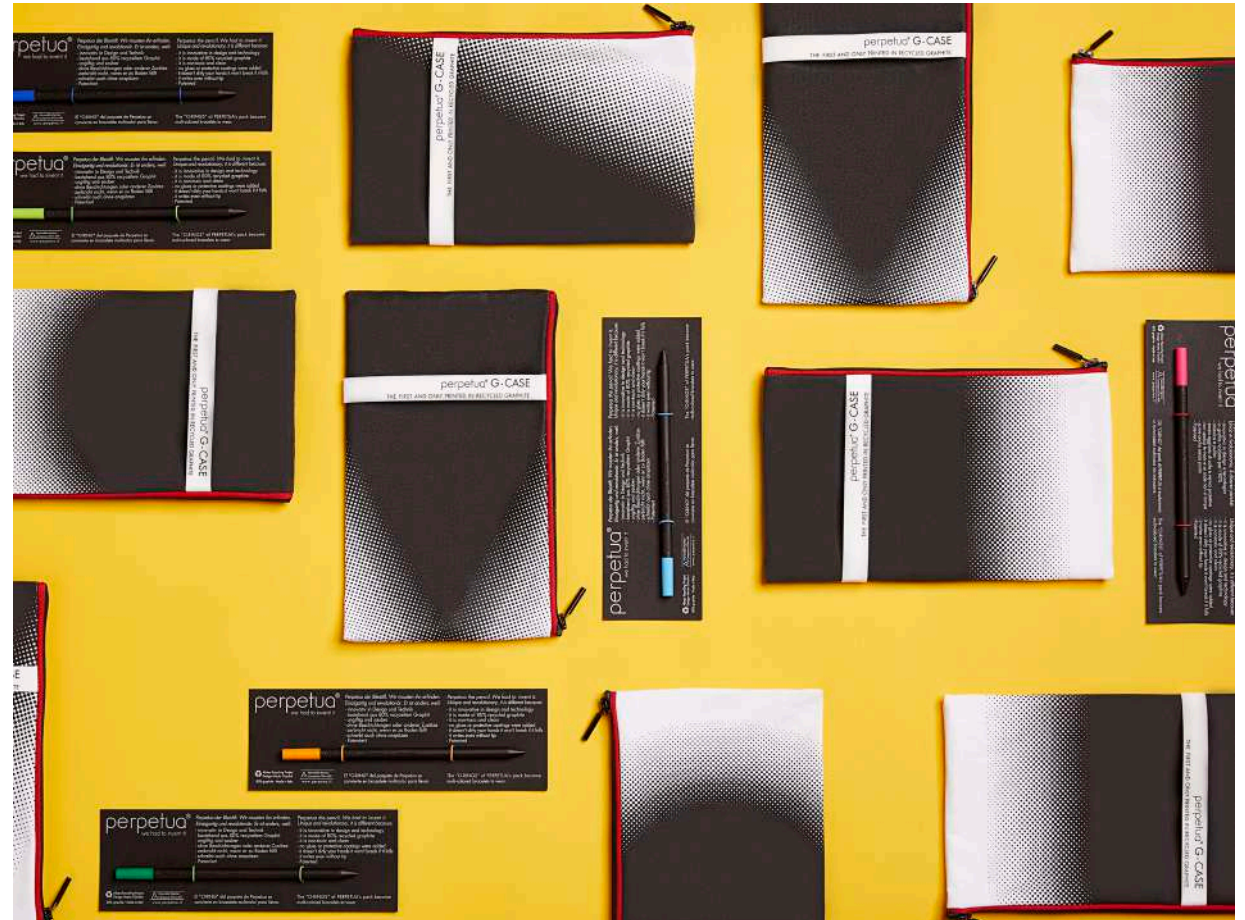

Display

The POS display is made in honeycomb cardboard, an extremely resistant material, light and durable. 100% recycled, it is available in different languages and can host up to 8 g_case. Designed by eng. Marco Neffat.

perpetua[®] tailor made

Tailor made is the division of Perpetua offering companies and individuals ad hoc projects. Several innovative customisation techniques transform Perpetua the pencil, its accessories and Perpetua recorder into exclusive objects for corporate communication purposes, celebrations and events.

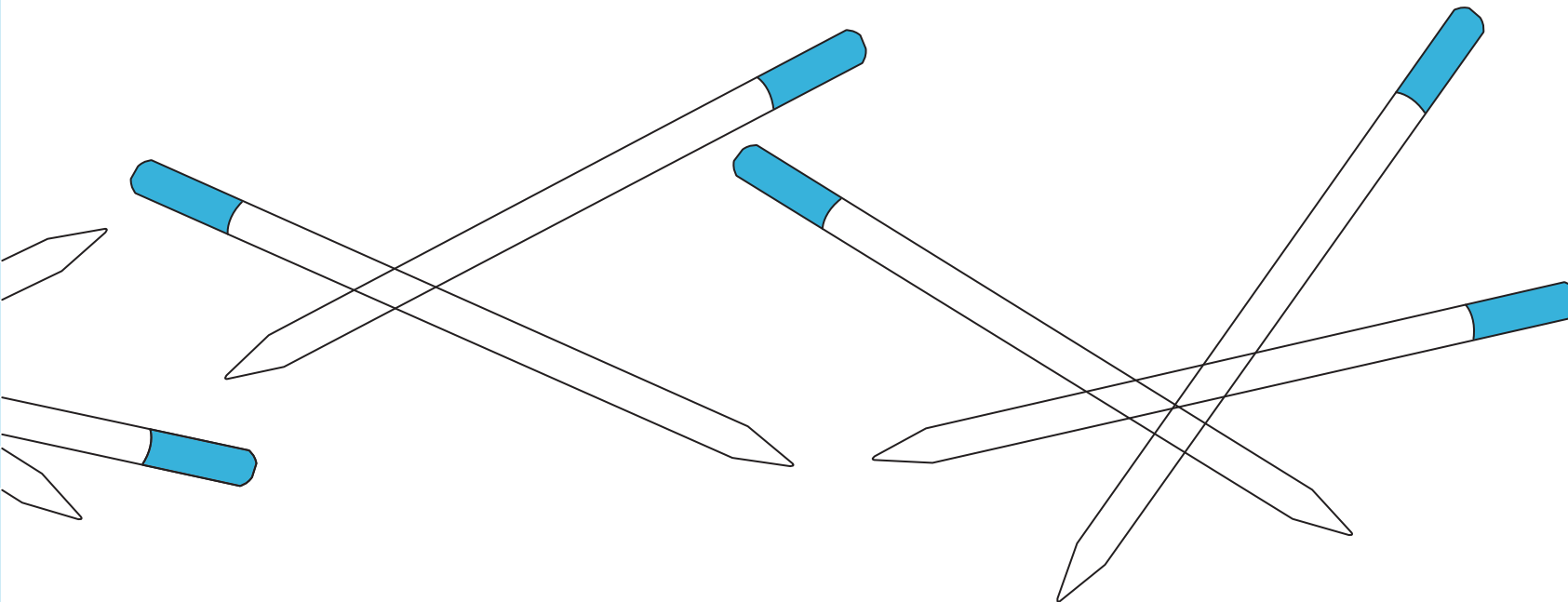

Perpetua for business

Perpetua was born to inspire change, showing that it is possible to produce the objects of our daily life in a sustainable way.

Perpetua becomes an unconventional way to present ourselves through a simple object, which has a distinctive design and countless possibilities of personalization.

Perpetua is based on the following values: creativity, design, environmental protection and material innovation.

Companies which share these values choose Perpetua to communicate their brand identity and mission.

Perpetua for Arclinea

Perpetua for the opening of the new Arclinea flagship store in Paris Beaupassage.



PERPETUA the pencil - tailor made

Perpetua exclusively for Starbucks Reserve Roastery

Unique kits of Perpetua have been created exclusively for all the Starbucks Reserve™ Roastery in the world - Milan, New York, Seattle and Chicago.



Perpetua monumental

Perpetua monumental is a project born from the cooperation with Fusarte. Perpetua the pencil pays homage to the beauty of historical Italian architecture and the huge legacy of its masterpieces.

perpetua® we had to invent it

- in grafite riciclata per l'80%
- se cade non si rompe
- non sporca le mani e se cade non si rompe
- non si spezza se si rompe
- non si spezza se si rompe

Una rivoluzione nella scrittura. Patentato.

Gallerie d'Italia
Piazza Scala
Milano

perpetua® we had to invent it

Perpetua è diversa dalle altre matite: nessun albero viene abbattuto per realizzarla; è in grafite riciclata per l'80%; se cade non si rompe. Nasce con una gomma colorata. Perpetua: riciclamo assieme scrivendo.

Perpetua the pencil is different from others because it's made with 80% recycled graphite; it doesn't dirty your hands and if it falls it doesn't break. It can be sharpened, but even writes when blunt. It has its own coloured rubber. Perpetua: recycling while writing.

Honorable Mention
Compasso d'Oro ADI
Design Marta Gardini
80% graphite
Alisea Recycling Project
Design Marta Gardini
www.perpetua.it

perpetua® we had to invent it

MONUMENTAL

Perpetua è diversa dalle altre matite: nessun albero viene abbattuto per realizzarla; è in grafite riciclata per l'80%; se cade non si rompe. Nasce con una gomma colorata. Perpetua: riciclamo assieme scrivendo.

Perpetua the pencil is different from others because it's made with 80% recycled graphite; it doesn't dirty your hands and if it falls it doesn't break. It can be sharpened, but even writes when blunt. It has its own coloured rubber. Perpetua: recycling while writing.

Honorable Mention
Compasso d'Oro ADI
Design Marta Gardini
80% graphite
Alisea Recycling Project
Design Marta Gardini
www.perpetua.it

Museo Reina Sofia Madrid

perpetua® we had to invent it

Honorable Mention
Compasso d'Oro ADI
Design Marta Gardini
80% graphite
Alisea Recycling Project
Design Marta Gardini
www.perpetua.it

Perpetua el lápiz diferente a todos. Reciclado en un 80%. No mancha las manos, ni se rompe. Se le puede sacar punta aunque también escribe sin ella. Incorpora su propia goma de borrar. Perpetua: recicla, escribiendo.

Perpetua the pencil is different from others because it's made with 80% recycled graphite; it doesn't dirty your hands and if it falls it doesn't break. It can be sharpened, but even writes when blunt. It has its own coloured rubber. Perpetua: recycling while writing.

perpetua® we had to invent it

MONUMENTAL

Perpetua è diversa dalle altre matite: nessun albero viene abbattuto per realizzarla; è in grafite riciclata per l'80%; se cade non si rompe. Nasce con una gomma colorata. Perpetua: riciclamo assieme scrivendo.

Perpetua the pencil is different from others because it's made with 80% recycled graphite; it doesn't dirty your hands and if it falls it doesn't break. It can be sharpened, but even writes when blunt. It has its own coloured rubber. Perpetua: recycling while writing.

Honorable Mention
Compasso d'Oro ADI
Design Marta Gardini
80% graphite
Alisea Recycling Project
Design Marta Gardini
www.perpetua.it

perpetua® we had to invent it

MONUMENTAL

Perpetua è diversa dalle altre matite: nessun albero viene abbattuto per realizzarla; è in grafite riciclata per l'80%; se cade non si rompe. Nasce con una gomma colorata. Perpetua: riciclamo assieme scrivendo.

Perpetua the pencil is different from others because it's made with 80% recycled graphite; it doesn't dirty your hands and if it falls it doesn't break. It can be sharpened, but even writes when blunt. It has its own coloured rubber. Perpetua: recycling while writing.

Honorable Mention
Compasso d'Oro ADI
Design Marta Gardini
80% graphite
Alisea Recycling Project
Design Marta Gardini
www.perpetua.it

perpetua® we had to invent it

MONUMENTAL

Perpetua è diversa dalle altre matite: nessun albero viene abbattuto per realizzarla; è in grafite riciclata per l'80%; se cade non si rompe. Nasce con una gomma colorata. Perpetua: riciclamo assieme scrivendo.

Perpetua the pencil is different from others because it's made with 80% recycled graphite; it doesn't dirty your hands and if it falls it doesn't break. It can be sharpened, but even writes when blunt. It has its own coloured rubber. Perpetua: recycling while writing.

Honorable Mention
Compasso d'Oro ADI
Design Marta Gardini
80% graphite
Alisea Recycling Project
Design Marta Gardini
www.perpetua.it

Palazzo Vecchio Firenze

perpetua® we had to invent it

Perpetua è diversa dalle altre matite: nessun albero viene abbattuto per realizzarla; è in grafite riciclata per l'80%; se cade non si rompe. Nasce con una gomma colorata. Perpetua: riciclamo assieme scrivendo.

Perpetua the pencil is different from others because it's made with 80% recycled graphite; it doesn't dirty your hands and if it falls it doesn't break. It can be sharpened, but even writes when blunt. It has its own coloured rubber. Perpetua: recycling while writing.

Honorable Mention
Compasso d'Oro ADI
Design Marta Gardini
80% graphite
Alisea Recycling Project
Design Marta Gardini
www.perpetua.it

Cupola del Brunelleschi Firenze 600 YEARS

perpetua® we had to invent it

Perpetua è diversa dalle altre matite: nessun albero viene abbattuto per realizzarla; è in grafite riciclata per l'80%; se cade non si rompe. Nasce con una gomma colorata. Perpetua: riciclamo assieme scrivendo.

Perpetua the pencil is different from others because it's made with 80% recycled graphite; it doesn't dirty your hands and if it falls it doesn't break. It can be sharpened, but even writes when blunt. It has its own coloured rubber. Perpetua: recycling while writing.

Honorable Mention
Compasso d'Oro ADI
Design Marta Gardini
80% graphite
Alisea Recycling Project
Design Marta Gardini
www.perpetua.it

Duomo Siena

perpetua® we had to invent it

Perpetua è diversa dalle altre matite: nessun albero viene abbattuto per realizzarla; è in grafite riciclata per l'80%; se cade non si rompe. Nasce con una gomma colorata. Perpetua: riciclamo assieme scrivendo.

Perpetua the pencil is different from others because it's made with 80% recycled graphite; it doesn't dirty your hands and if it falls it doesn't break. It can be sharpened, but even writes when blunt. It has its own coloured rubber. Perpetua: recycling while writing.

Honorable Mention
Compasso d'Oro ADI
Design Marta Gardini
80% graphite
Alisea Recycling Project
Design Marta Gardini
www.perpetua.it

Spoletto

perpetua® we had to invent it

Perpetua è diversa dalle altre matite: nessun albero viene abbattuto per realizzarla; è in grafite riciclata per l'80%; se cade non si rompe. Nasce con una gomma colorata. Perpetua: riciclamo assieme scrivendo.

Perpetua the pencil is different from others because it's made with 80% recycled graphite; it doesn't dirty your hands and if it falls it doesn't break. It can be sharpened, but even writes when blunt. It has its own coloured rubber. Perpetua: recycling while writing.

Honorable Mention
Compasso d'Oro ADI
Design Marta Gardini
80% graphite
Alisea Recycling Project
Design Marta Gardini
www.perpetua.it



MONUMENTAL

TORINO - LA MOLE

perpetua® we had to invent it

Perpetua è diversa dalle altre matite: nessun albero viene abbattuto per realizzarla; è in grafite riciclata per l'80%; se cade non si rompe. Nasce con una gomma colorata. Perpetua: riciclamo assieme scrivendo.

Perpetua is different from other pencils: no tree has been cut down to produce it; it's made of 80% recycled graphite; it won't break if it falls. A revolution in writing. Patentato.

Design Marta Gardini
80% graphite - Made in Italy
www.perpetua.it

perpetua® we had to invent it

MONUMENTAL

SANT'ANTONIO DI PADOVA

Perpetua è diversa dalle altre matite: nessun albero viene abbattuto per realizzarla; è in grafite riciclata per l'80%; se cade non si rompe. Nasce con una gomma colorata. Perpetua: riciclamo assieme scrivendo.

Perpetua the pencil is different from others because it's made with 80% recycled graphite; it doesn't dirty your hands and if it falls it doesn't break. It can be sharpened, but even writes when blunt. It has its own coloured rubber. Perpetua: recycling while writing.

Design Marta Gardini
80% graphite - Made in Italy
www.perpetua.it

Firenze

perpetua® we had to invent it

Perpetua è diversa dalle altre matite: nessun albero viene abbattuto per realizzarla; è in grafite riciclata per l'80%; se cade non si rompe. Nasce con una gomma colorata. Perpetua: riciclamo assieme scrivendo.

Perpetua the pencil is different from others because it's made with 80% recycled graphite; it doesn't dirty your hands and if it falls it doesn't break. It can be sharpened, but even writes when blunt. It has its own coloured rubber. Perpetua: recycling while writing.

Honorable Mention
Compasso d'Oro ADI
Design Marta Gardini
80% graphite
Alisea Recycling Project
Design Marta Gardini
www.perpetua.it

Perpetua recorder the magnetic notebook exclusively for Starbucks Reserve Roastery

Exclusively for its first anniversary, Starbucks Reserve™ Roastery in Milan chose Perpetua recorder the magnetic notebook. Recorder becomes, for the occasion, a tribute to the fine Palladian flooring of the historical Palazzo delle Poste in Piazza Cordusio in Milan. What makes the coating unique and valuable is the use of the typical Candoglia marble, recognisable by its white/pink colour, the same used for the facades of the Milan Cathedral.



Perpetua recorder the magnetic notebook for TEDxVicenza 2019 - Transition

Perpetua recorder the magnetic notebook is the official gift of the fifth edition of TEDxVicenza 2019. A highly innovative object in full harmony with TEDx values. Recorder is the result of patents and innovative technologies combined with the creativity and genius Italian minds.

Perpetua g_case exclusively for Coincasa home collection

The Coincasa Spring 2019 collection is a tribute to the 100 years anniversary of the Bauhaus school, the famous academy of architecture, art and design of Germany where - from 1919 to 1933 - taught artists, architects, craftsmen, designers from different cultures.

Coincasa dedicates a special tribute to Bauhaus with a collection of iconic furnishing objects and accessories: Perpetua the pencil and Perpetua g_case could not miss.

Geometric patterns and intense colours alternate with eco-friendly materials to give your home a new energy!

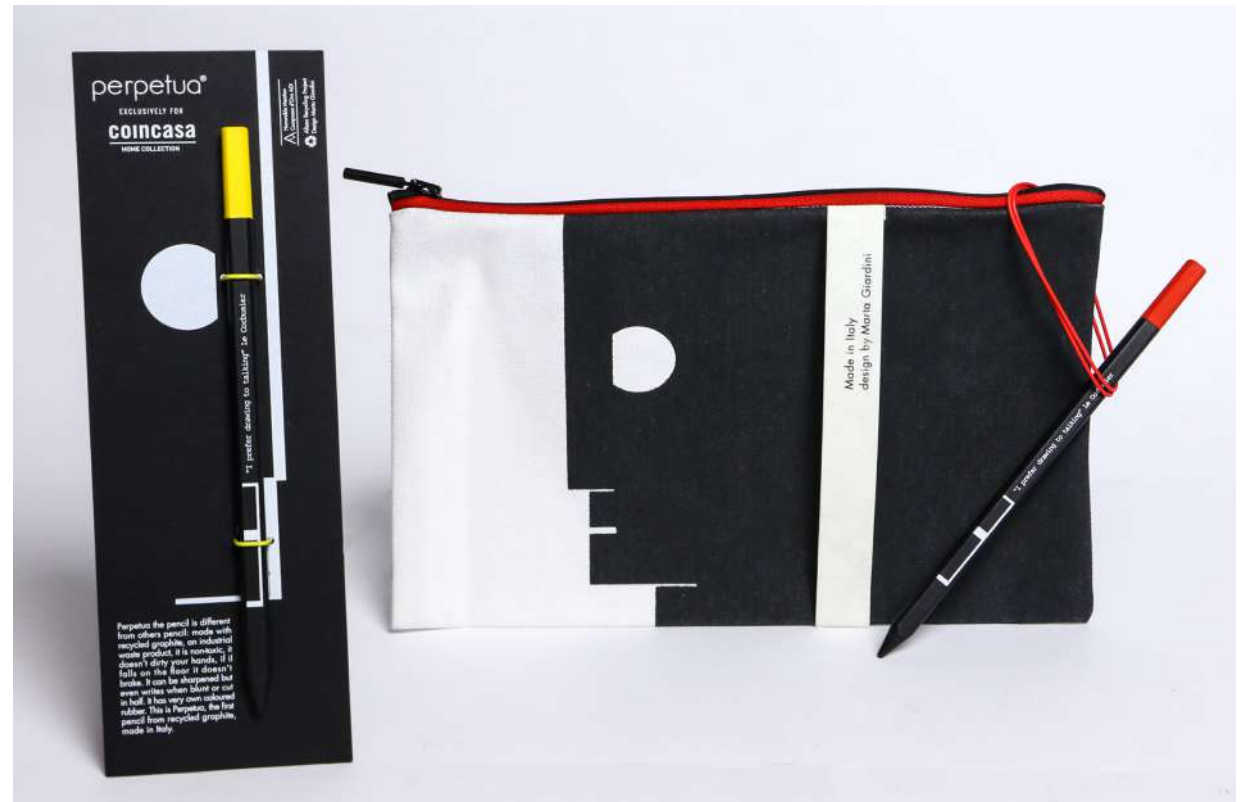

Perpetua g_case for Oracle

Oracle Corporation, IT leader company choose Perpetua g_case.

perpetua[®] Il team



Susanna
CEO & Founder



Viviana
Administration & Finance



Graziano
Graphic Designer



Pier Marco
Junior Graphic Designer



Vera
Business Development Manager



Laura
Account Manager



Sheila
Account Manager



Mara
Account Manager



Giorgia
Marketing & Communication



Alvise
Junior Copywriter



Marta
Designer

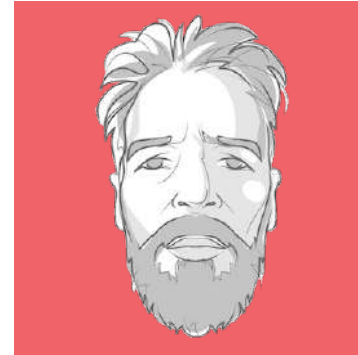

Giorgio
Logistic & Warehouse Manager

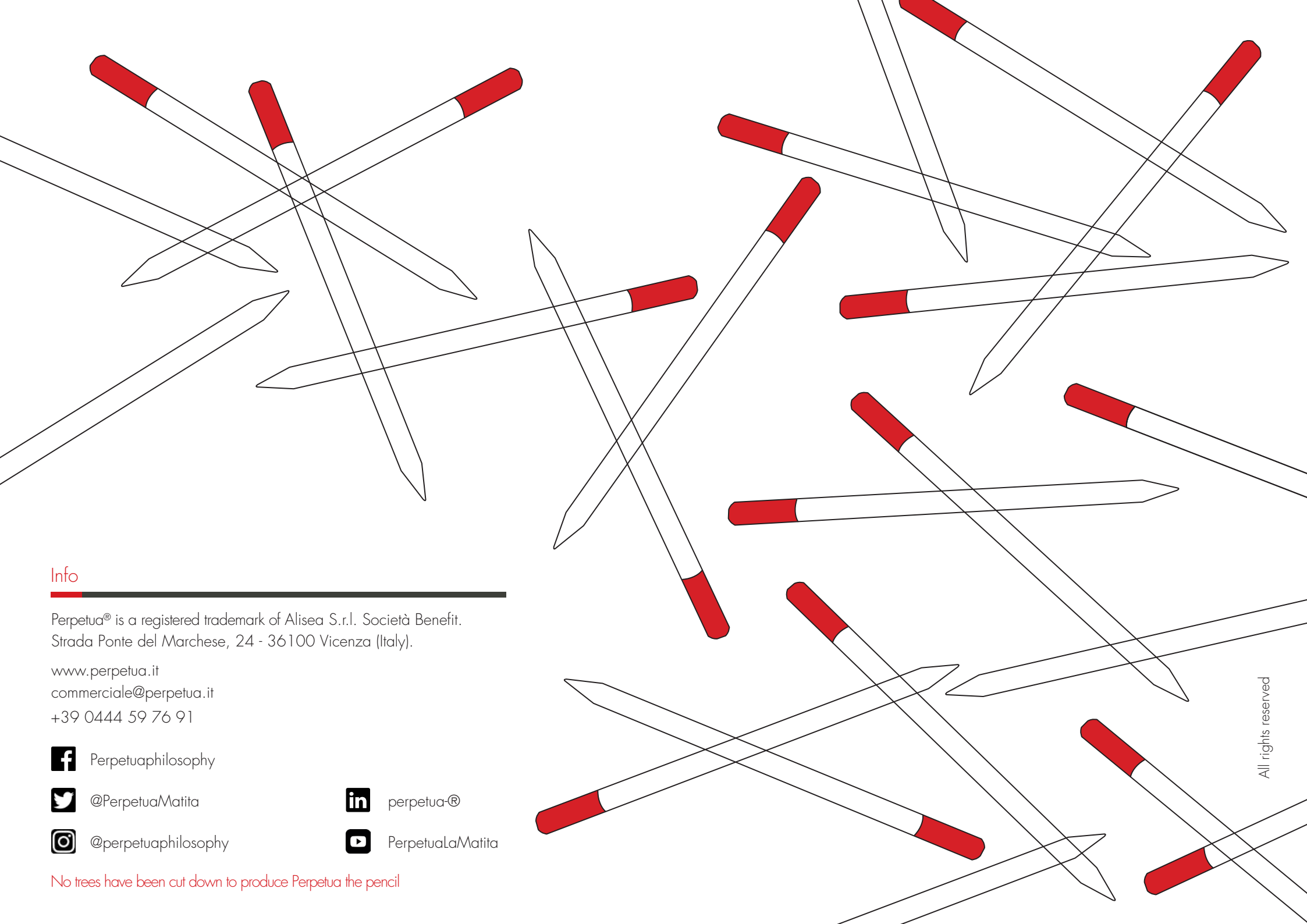

Info

Perpetua® is a registered trademark of Alisea S.r.l. Società Benefit.
Strada Ponte del Marchese, 24 - 36100 Vicenza (Italy).

www.perpetua.it
commerciale@perpetua.it
+39 0444 59 76 91

 Perpetuaphilosophy

 @PerpetuaMatita

 @perpetuaphilosophy

 perpetua®

 PerpetuaLaMatita

No trees have been cut down to produce Perpetua the pencil

All rights reserved